

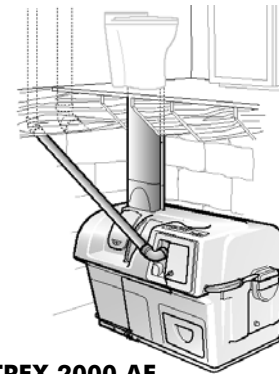

CENTREX 2000 AF FAMILY OWNER'S MANUAL

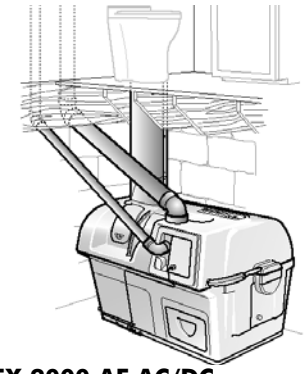

CENTREX 2000 AF



CENTREX 2000 AF AC/DC

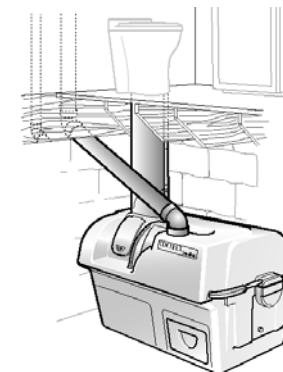

CENTREX 2000 AF NE

Electrical Specifications	2000	2000 NE	2000 AC/DC
Maximum Amps	2.4	NA	2.4/NA
Fan Watts (Required or Optional Hook-up)	35 req.	1.4 opt.	35 req./ 1.4 opt.
Heater Watts (When on)	370	NA	370
Average Power Use In Watts (Heater on 1/2 time)	200	NA	200

Oasis Montana Inc
 Authorized Sun-Mar Dealer
 Stevensville, MT 59870
 1-877-627-4768 (toll-free)
<http://www.eco-potty.com/>



Product Info: (905) 332-1314 Fax: (905) 332-1315 Tech. Service: (888) 341-0782
 E-mail: compost@sun-mar.com <http://www.sun-mar.com>

600 Main St
 Tonawanda NY
 14150-0888 USA

5370 South Service Rd.
 Burlington, ON
 L7L 5L1 CANADA



Certified to NSF/ANSI Standard 41

Standard 41

Certified for liquid containment,
 odors, and solid end products in
 both residential and cottage use

RATED CAPACITY

Weekend & Vacation Use (Cottage Use)

NE Units; 5 Adults or families of 7 or
 Electric Units; 6 Adults or families of 8

Residential & Continuous Use

NE units; 3 Adults or a family of 5 or
 Electric Units; 4 Adults or families of 6

Oasis Montana Inc

Authorized Sun-Mar Dealer

Stevensville, MT 59870

1-877-627-4768 (toll-free)

<http://www.eco-potty.com/>

OWNER'S MANUAL

CONTENTS

Introduction	How your composting toilet Works How Composting Works 3 The Composting Chamber 3 Compost Finishing Drawer 3 Evaporation Chamber 4 Winter Use 4 CENTREX 2000 AF Family Explosion Drawing 5 CENTREX 2000 AF Family Part Numbers 6 Wiring Diagram 6 Dry Toilet Explosion Diagram 7	3-7	Chapter 3	Start Up and Use Initial System Start Up 17 Annual Start Up 18 Periodic Check Up 18 Ongoing Maintenance 19	17-19
Chapter 1	Inspection Check for Damage 8 Check for Parts and Functionality 8 Placement of AF Dry Toilet 8	8	Chapter 4	Compost Troubleshooting Aerobic Compost Requirements 20 Compost Too Wet 21 Compost Too Dry 21 Waste not Breaking Down 22 Lumps 22 Drum Too Full 22 Flies 23	20-23
Chapter 2	Installation CENTREX 2000 AF Rough in Dimensions 9 AF Dry Toilet Rough In Dimensions Included in Your Kit 10 Installing the AF Toilet Base The Transition Piece 11 Determining if an Extension Pipe Piece is Needed 12 Assembling Extension Pipe Pieces 12 Finishing the AF Toilet Installation 12 Adjusting the Air Intake 13 Installing optional Vent on Toilet Cutting Holes in the Toilet Chute 13 Drain Installation 13 Handling Effluent 14 Vent Piping Location 14 Adjusting the Fan Gate 14 Vent Piping Installation 14 Leading the Vent Through the Roof The Diffusor 15 Electrical Considerations 15 12 Volt Fan Installation 16	9-15	Chapter 5	Mechanical Troubleshooting Urine Odour In Washroom 24 Occasional Urine Odour Outside 25 Sewage Odour when drum turns 25 Fan Noisy 25 Fan Not Working 26 Liquid Buildup/ Lack of Evaporation 26 Overflowing Liquid 26 Heating System Not Working 27 Liquid In Finishing Drawer 28 Drum Will Not Stay Vertical 28 Drum Will Not Turn 28 Drum Door Not Opening/ Closing 29 Waste Not Exiting Waste Pipe 29	24-29
				Warranty Information Basic Maintenance	30 31

Introduction

HOW YOUR COMPOSTING TOILET WORKS

The key to the success of the “CENTREX 2000 AF Family” lies in it's three chamber design. Each of the three chambers; composting, compost finishing, and evaporation have their own independent environments for optimum efficiency.

Composting is a natural recycling process where human waste and toilet paper are broken down by microbes into minerals and converted back to earth. Heat, oxygen, organic material and moisture are needed to transform this waste into good fertilizing soil, perfect for your flower beds.

Oxygen is provided by the ventilation system, and by tumbling of the composting drum. Additional organic material is introduced by adding a compost bulking mixture. The waste entering the toilet is approximately 90% water content. Any excess liquid which is not absorbed will collect on the floor of the unit (evaporation chamber) where it may be evaporated into water vapor and carried back to the atmosphere through the venting system. The remaining waste material is transformed into an inoffensive earth-like substance.

The Composting Chamber

The composting chamber is in the form of a Bio-drum which holds the natural compost heat, provides the necessary mass to maintain a good compost, and is rotated by turning the handle to achieve perfect mixing and aeration.

During mixing, both the input door and the output doors will remain closed. When the drum returns to the top dead centre position ready to receive more waste, the doors will remain open.

A drum stopper, on the right side of the unit (handle side) automatically holds the Bio-drum in a top dead

center position so that it is always positioned to receive new material.

To ensure that the compost remains moist, but does not get too wet (between 40 and 60% moisture content is ideal), any excess liquid which the compost cannot absorb drains through a screen in the bottom of the drum directly onto an evaporating tray beneath the screen, and from there, overflows into the larger evaporating chamber. The evaporating tray can be removed periodically to remove peat moss debris that has accumulated.

Compost Finishing Drawer

The compost finishing drawer is at the extreme right of the unit below the composting drum, and just above the evaporating chamber. Compost from the drum is isolated in the drawer where it is allowed to 'finish' composting. For seasonally used units, several drawers of finished compost are normally removed at the beginning of the season. Otherwise some composted material can be extracted into the drawer and left there for 2 months until it is time to remove more compost from the drum.

Evaporating Chamber

The third chamber is the floor of the Sun-Mar “CENTREX 2000 AF” which forms the evaporation chamber from where excess liquids are evaporated. You will frequently see liquid in this area.

Basic Maintenance Instructions

Sealand toilet and 'Centrex Family' Central Units

The toilet is porcelain and should be cleaned with hot water or bio-degradable products to avoid damage to the compost. If required 'Compost Quick' or Baking Soda can be used diluted in hot water.

Three times a week weekly maintenance:

Turn drum to reveal waste inlet hole through access port and add compost mix at the rate of 1 cup (250ml) per person per day. (Scoop provided is 2 cups or 500ml)
Rotate handle clockwise to mix contents of Bio-drum and give 6 complete revolutions of the drum - (36-40 rotations of the handle). Ensure that the drum door opening is in the vertical position at the end after hearing the 'click' of the catch.

Check compost volume and condition in Bio-drum and:

If the waste in the Bio-drum is too wet add wood shavings to improve aeration.
If composting is too slow add a compost accerant every second week, and ensure that the drum is not more than 1/2 full. If it is, follow the instructions for the emptying cycle.

Monthly maintenance and emptying cycle:

Rake out evaporation chamber with rake provided. For units with one, (Centrex 1000, 2000, & 3000 units) the black evaporating tray should be removed, solid matter tipped into the finishing tray and then replaced beneath the drum screen.
Empty out the collection chamber ready to receive fresh material.

Attention: the composting unit must remain plugged in to an electrical outlet continuously to function odourlessly. The AC/DC units should have both fans running while used in electric mode to prevent recirculation between vent stacks. If you will be away from the residence where the composting unit is installed for longer than three days, the power may be disconnected while the composting unit lays dormant.

In Electric or AC/DC units, air is pulled through intake holes at the rear of the unit and down the toilet; over the evaporating chamber, and up the 2"(50mm) vent stack which exits from the front of the composting unit when AC power is being used.

When using the NE or AC/DC units and AC power is unavailable, natural draught caused by the chimney effect combined with a 12 volt fan draws air into the unit and up the 100mm vent stack.

In Electric or AC/DC units using the AC mode, the evaporation process is further assisted by a thermostatically controlled heating element in a separate sealed compartment under the evaporating chamber. This heater is on when there is liquid in the evaporating chamber, and largely off when the chamber is dry. The heating system maintains warmth in the evaporating chamber, and the indirect warmth assists the composting

Winter Use

Because "Sun-Mar" units are made of fiberglass and high grade stainless steel, freezing temperatures will not damage the composting unit. Composting action decreases as the temperature drops, so for extended use, the toilet should be kept constantly at or above 55-60 F(13-15 C) degrees. All exposed 2"(50mm) vent stack should be insulated to minimize the condensation in the pipe and avoid ice blockages.

In extreme temperatures, an additional source of heat will also be required. It is also advisable for residential applications in extreme climates to install an electric plumbing tape inside the 2"(50mm) vent to prevent icing.

If the compost is frozen in the drum, the unit may be used periodically as a "holding tank", until the compost warms up and the microbes emerge from dormancy. Space should be made in the drum to accommodate winter use. The drum should NOT be rotated when the compost is frozen.

Composting Drum: Waste and bulking mixture collect for decomposition

Finishing Drawer: Where compost is put to 'finish'

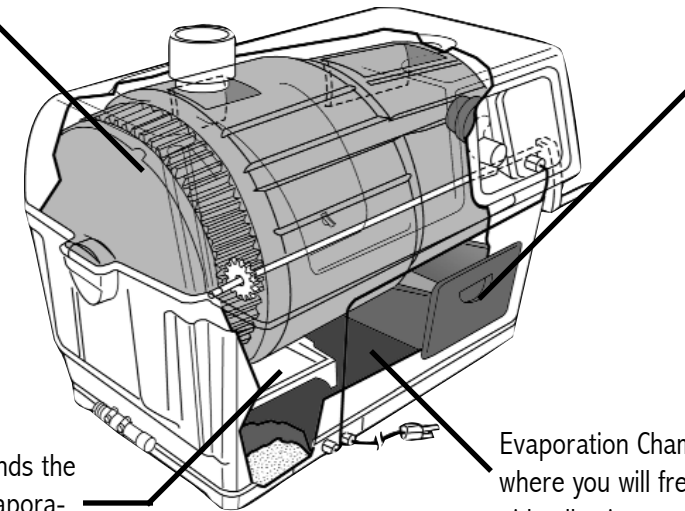

Evaporation Tray: Extends the surface area of the evaporation chamber

Evaporation Chamber: This is where you will frequently see liquid collecting.

EXPLOSION DRAWING OF COMPOSTING UNIT

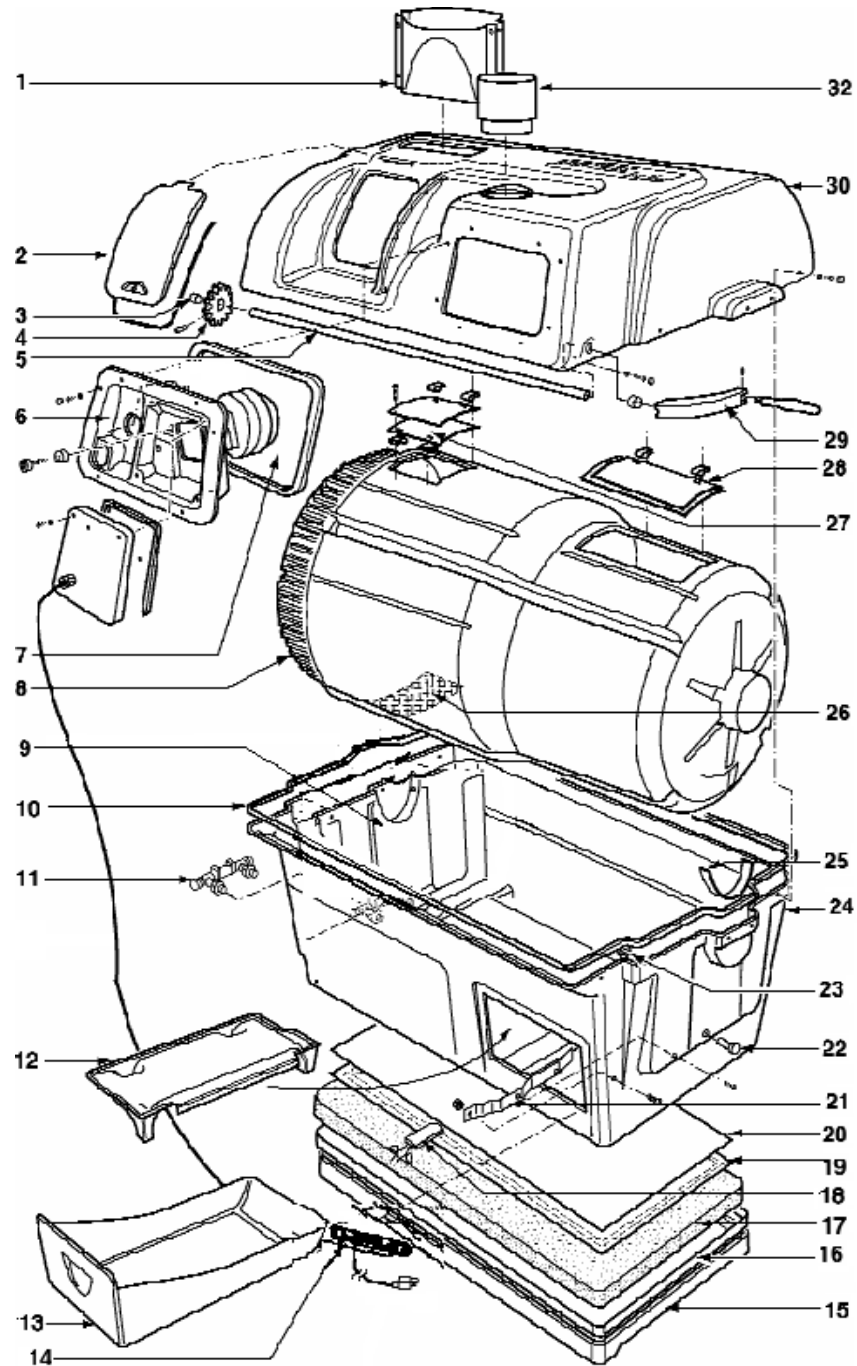

WARRANTY

SUN-MAR Corp. warrants the original purchaser that this toilet is free from defects in material and workmanship under normal house or cottage use. SUN-MAR Corp. will furnish new parts for any part that fails within three years provided that our inspection shows that such failure is due to defective material or workmanship. Any part supplied by us to replace another part is warranted for the balance of the original warranty period.

This warranty does not cover:

1. Damage resulting from neglect, abuse, accident or alteration; or damage caused by fire, flood, acts of God or any other casualty.
2. Parts and accessories not sold or manufactured by SUN-MAR Corp. or any damage resulting from the use of such items.
3. Damage or failure resulting from failure of the purchaser to follow normal operating procedure outlined in the Owner's Manual or in any other printed instructions.
4. Labor and services charges incurred in the removal and replacement of any parts found defective under the terms of this warranty.
5. All returns to the factory must be made freight prepaid. All shipments from the factory are made F.O.B. the factory.

This warranty is in lieu of all other warranties expressed or implied, and no person is authorized to enlarge our warranty responsibility, which is limited to the terms of this certificate. The Company reserves the right to change, improve or modify its products without obligation to install these improvements on equipment previously manufactured.

Symptom	Cause	Remedial Action	Prevention
Drum Will Not Turn (Cont'd)	Drum fallen from bearings fallen.	Have your serial number ready. If the drum has fallen, contact your Sun-Mar dealer immediately. We will make sure your problem is fixed quickly.	Not a common repair.
	Drum too full	See Section on "Compost Troubleshooting- Drum Too Full"	Follow items in prevention column for "Drum Too Full"
Drum Door Not Opening/ Closing Properly <i>(Compost will drop into the finishing drawer even when the drum is not being rotated backwards to extract compost).</i>	Hinges Stuck	Drum hinges have compost caked on them. Spray with vinegar and water solution and clean with nylon brush. This will push the obstruction away so the door swings freely.	Drum should never be more than 1/2 full.
	Hinge(s) broken	Call your Sun-Mar dealer to obtain a replacement drum hinge.	

CENTREX 2000 A/F PART NUMBERS & DESCRIPTIONS

#	PART	DESCRIPTION	#	PART	DESCRIPTION
1.	PP-AIRFL-0005XX	AF Transition Piece	17	PP-INSU0-0187XX	Insulation (Electric & AC/DC)
2.	AO-ACCEP-0481BX	Access Port	18	AO-THERA-0001BX	Thermostat Sweden
3.	PM-BUSH0-0173	Bushing 1/2"(13mm) OD	18	AO-THERA-0001AX	Thermostat
4.	PP-GEAR0-0173XX	Nylon Drive Gear	19	AO-HEATE-0311XX	Heating Element C9286-1
5	AO-SHAFA-0852XX	Stainless Steel Drive Shaft	20	PM-ALUMS-0811XX	Aluminum Sheet
6	AO-FAN_A-0315XX	Fan Assembly (Electric & AC/DC)	21	AO-DRUML-0469BX	Drum Locker
7	PP-FAN_a-0315DD	Rubber Gasket	22	PP-SCRE0-0827XX	Drum Lock Release Knob
8	PP-DRUM0-0800XX	Centrex 2000 Drum	23	PP-GASK0-0188BX	Rubber U Channel
9	PP-BEARP-0758RX	Bearing Plate	24	PF-TANK2-0801XX	Centrex 2000 Tank
10	PP-GASK0-0188BX	Rubber U Channel	25	PP-BEARS-0787BX	Bearing Strip
11	AP-DRAI0-0306XX	25mm Drain Assembly	26	AM-DRUMS-0329XX	Drum Screen
12	PF-EVAPT-0789XX	Evaporation Tray	27	AO-DRUMD-2004XX	Drum Door
13	PF-DRAW1-0764XX	Centrex 2000 Drawer	28	AO-DRUMD-2004XX	Drum Door
14	PO-ELECB-0001AX	Electric Box Assembly(Electric and AC/DC)	29	AO-HANDL-3000XX	Swivel Handle
15	PF-HEAT2-0803XX	Heater Base (Electric & AC/DC)	30	PP-TOPC2-0802CX	Centrex 2000 AC/DC Top
16	PP-GASK0-0188BX	Rubber U Channel	30	PP-TOPC2-0802BX	Centrex 2000 Top Kit
			30	PP-TOPC2-0802DX	Centrex 2000 NE Top
			31	AO-PIPEP-0305XX	100mm Vent Inlet (NE)

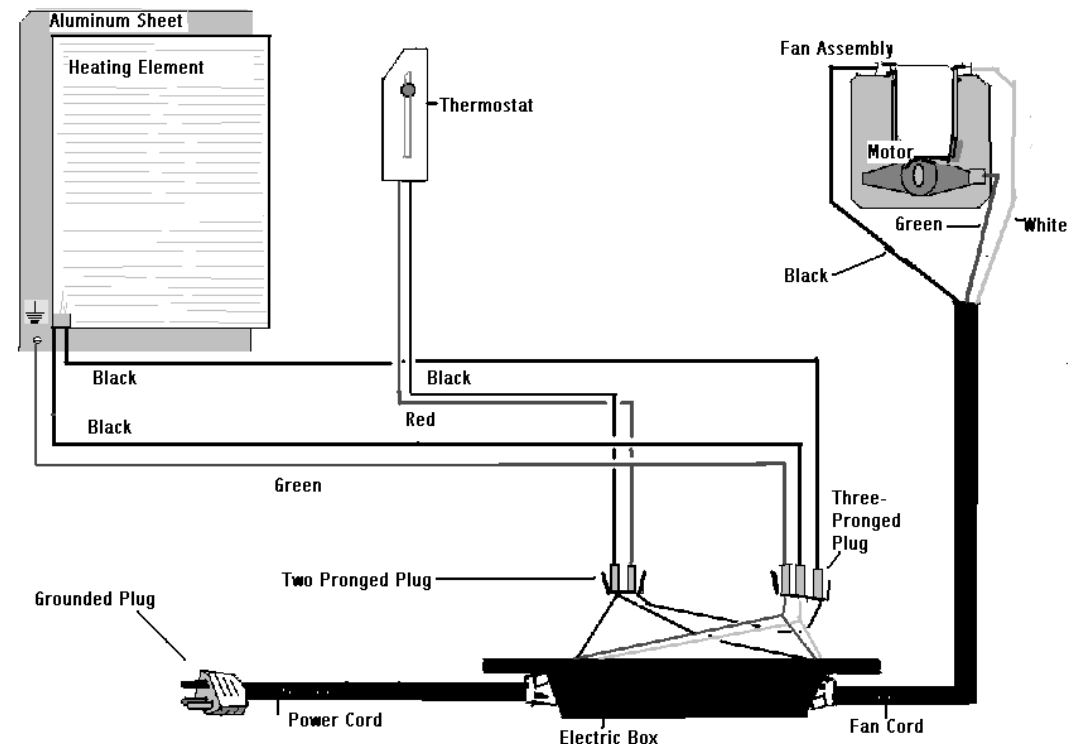

EXPLOSION VIEW & PARTS FOR DRY TOILET

#	PART	DESCRIPTION	#	PART	DESCRIPTION
1	PP-TOILS-0208CX	Toilet Seat White	6	PM-SCRE0-0251BX	#8 X 1/2" (16mm) Stainless Steel Flat Head Screw
	PP-TOILS-0208DX	Toilet Seat Bone			
2	PF-BOWLL-0246FX	AF Bowl Liner	7	PP-WASH0-0274XX	CKS Plastic Washer
3	PP-CAP00-0587XX	Tap Cap Bone	8	PP-SNAPC-0273XX	Snap Cap (Bone)
	PP-CAP00-0587WX	Tap Cap White		PP-SNAPC-0273WX	Snap Cap (White)
4	PM-SCRE0-0250XX	#8 X 3/4" (19mm) Flat Head Philips Screw	9	PP-AIRFL-003XX	Toilet Chute
			10	PF-AIRFL-0002BX	Toilet Base Bone
5	PF-AIRFL-0001BX	Toilet Top Bone		PF-AIRFL-0002XX	Toilet Base White
	PF-AIRFL-0001XX	Toilet Top White			

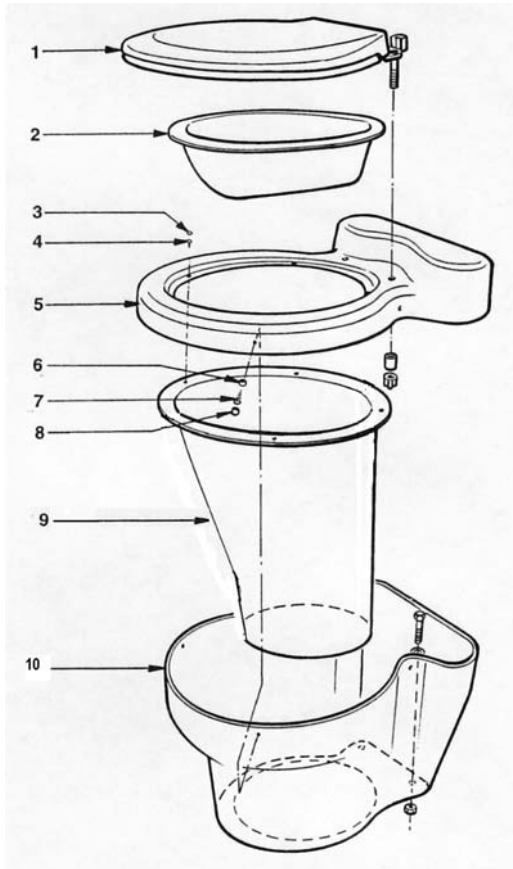

Symptom	Cause	Remedial Action	Prevention
Heating System Not Working (Cont'd) (Electric and AC/DC)	Heating Element Failure	Have your serial number ready and call your Sun-Mar dealer for a replacement. (Detailed instructions are included with the replacement part) Please note: Because this part is not easy to replace, and because there is far less chance that you will need this part than a thermostat; we recommend trying to replace the thermostat first.	DO NOT use a pressure hose around the base of the unit. Install Unit so that weather and/or groundwater cannot get at the base of the unit.
	Liquid in Finishing Drawer	Drum Screen Clogged	Use a flashlight to see the screen at the bottom of the drum. Scrub screen with wire brush. The overflow drain should be hooked up.
	Unit tilted to the right	Use a 1/4 - 1/2" (6mm - 12mm) wedge piece under the right side of the unit to drain liquid more easily towards the overflow drain of the unit.	Install toilet level or tilting slightly to the left, DO NOT install the toilet tilting forwards or to the right. If you are unsure of the grade of the floor, install it with a wedge piece.
	Condensation running down vent stack	Liquid will be clear or yellowish in appearance. Make sure all vent pipe exposed to the outdoor is well insulated and there are no horizontal runs.	Remove horizontal sections of vent pipe and insulate all exposed 2" (50mm) venting.
Drum Will Not Stay Vertical	Drum Locker Broken	Have serial number ready and call your Sun-Mar dealer for a replacement part.	When returning the drum to top dead center position, do not bang against drum locker with excessive force. Remember to pull out the drum locker button before rotating the drum backwards.
Drum Will Not Turn	Set screw securing handle to shaft has broken	Drill out set screw and replace, or get handle replacement kit (instructions included).	Not a common repair.
	Steel pin securing gear wheel to shaft has broken	Have your serial number ready and call your Sun-Mar dealer for a replacement Small Gear Kit.	Keep composting drum from becoming overloaded. This puts undue strain on the nylon gear.

Symptom	Cause	Remedial Action	Prevention
Overflowing Liquid (Cont'd)	Drains Blocked	<p>1. Rake peat moss away from back two corners of Centrex 2000 A/F. These are the "buildup" areas. If drains are still clogged, proceed to step 3.</p> <p>2. Check drain line for kinks, blockages or upward bends. Remove and flush if blockages present, unkink if bent and ensure that the drain pipe is sloping downward. If your drain pipe is in order, proceed to step 3.</p> <p>3. Use a wire to poke peat moss out of the drain assembly at the back. You will notice if this is clogged because you will see a brown spot through the opaque assembly. (Only peat would make it through the drum screen). If there is no peat clog, or the problems continue, backwash the unit quickly with a hose by applying the nozzle to one of the drain assemblies and turning it on and off very quickly. If the bottom of the unit is full of liquid, you may wish to remove some prior to back-washing. A shop-vac works well.</p>	<p>1. A clogged drain is not very likely to happen if you rake your evaporating chamber 1-2 times a season (cottage use) and 3-4 times for continuous use.</p> <p>2. Use premium 1"(25mm) hose for the drain line. A good hose will be less likely to kink. Use elbows or fittings around bends to prevent kinks.</p> <p>3. Use the proper bulking material.</p>
Heating System Not Working (Electric and AC/DC)	Test to determine whether failure has occurred	Pull drawer out and put your hand in the evaporation chamber (Not in the liquid). If there is no warmth rising from the floor of the unit, your heating system is not working. It is most commonly the thermostat that has failed. If you notice a lack of evaporation, but there is still warmth in the heating chamber, see the Liquid Buildup section on page 26 for solutions.	A ground fault circuit interrupter (GFI) is recommended to protect your Centrex 2000 A/F from power surges that could cause your heating system to malfunction.
	Thermostat Failure	Have your serial number ready and call Sun-Mar for a replacement. (Detailed instructions are included with the replacement part) If the insulation behind the thermostat access cover is moist or discolored, or heating does not work after the new thermostat has been connected, then the heating element has failed.	Your thermostat and fan are the two constantly moving parts on the unit, and so are the most likely to fail. Both are easy to replace.

Chapter 1 Inspection

Inspecting the unit for damage	<p>i) If there is any visible damage to the carton- the contents of carton MUST be inspected before signing bill of lading. Damaged units should be refused. Call Sun-Mar immediately.</p> <p>ii) Before signing the shipping papers and dismissing the driver.- ensure that the carton contents have been inspected.</p> <p>iii) If the shipper has left- Report the damage immediately to the transport company and call Sun-Mar.</p> <p>iv) Soon after delivery, remove the Centrex 2000 AF carefully from the carton- If there is hidden damage, or for any service Questions, contact Sun-Mar to determine the best course of action.</p>
Check Carton Contents and Familiarize Yourself with the Centrex 2000 A/F	<p>Check that the carton contains the vent stack (pipe, fittings, roof flashing and diffusor); rake, drain hose and fittings, extension pipe piece and transition piece. Notify Sun-Mar if you are missing anything.</p> <p>i) Turn the drum handle clockwise to rotate the Bio-Drum for mixing and aeration. (The drum rotates counter-clockwise and the drum door closes). This is how you will rotate the drum.</p> <p>ii) Lift and remove the access door and rotate the drum until the drum opening is opposite the access door for adding a compost bulking mixture. This is how you will add bulking mixture to the drum</p> <p>iii) Plug the unit's electrical cord into a standard electrical outlet, and feel the air movement from the vent outlet at the top left of the unit to ensure the vent system is working properly (Electrical or AC/DC)</p> <p>v) Pull out the compost finishing drawers at the bottom left and right of the unit.</p> <p>vi) After the unit has been plugged in for ten minutes, place a hand on the floor of the evaporating chamber (the inside floor of the unit) to check it is warm to the touch, and that the heater is working properly.</p> <p>vii) Affix the "WARNING/CLEANING" sticker to the underside of the toilet seat cover, and check that another is on the access port of the composting unit.</p> <p>viii) Check the AF "Dry Toilet" for any damage.</p>
Placement of AF Dry Toilet	<p>Ensure that the floor joists are not in the way and that there is an unobstructed 10"(254mm) diameter passage from the underside of the AF "Dry Toilet" to the top of the transition piece. The 10"(254mm) hole should be centered 13"(33cm) from the back wall and at least 6.5" (165mm) from the side wall in the room where the toilet will be installed.</p> <p>The transition piece on the top of the composting unit should be located so that the center line of the transition piece is directly below the center of the 10"(254mm) circular cutout which will be made in the bathroom floor above. The transition piece should be completely vertical on the composting unit.</p>

Chapter 2
Installation
ROUGH IN DIMENSIONS

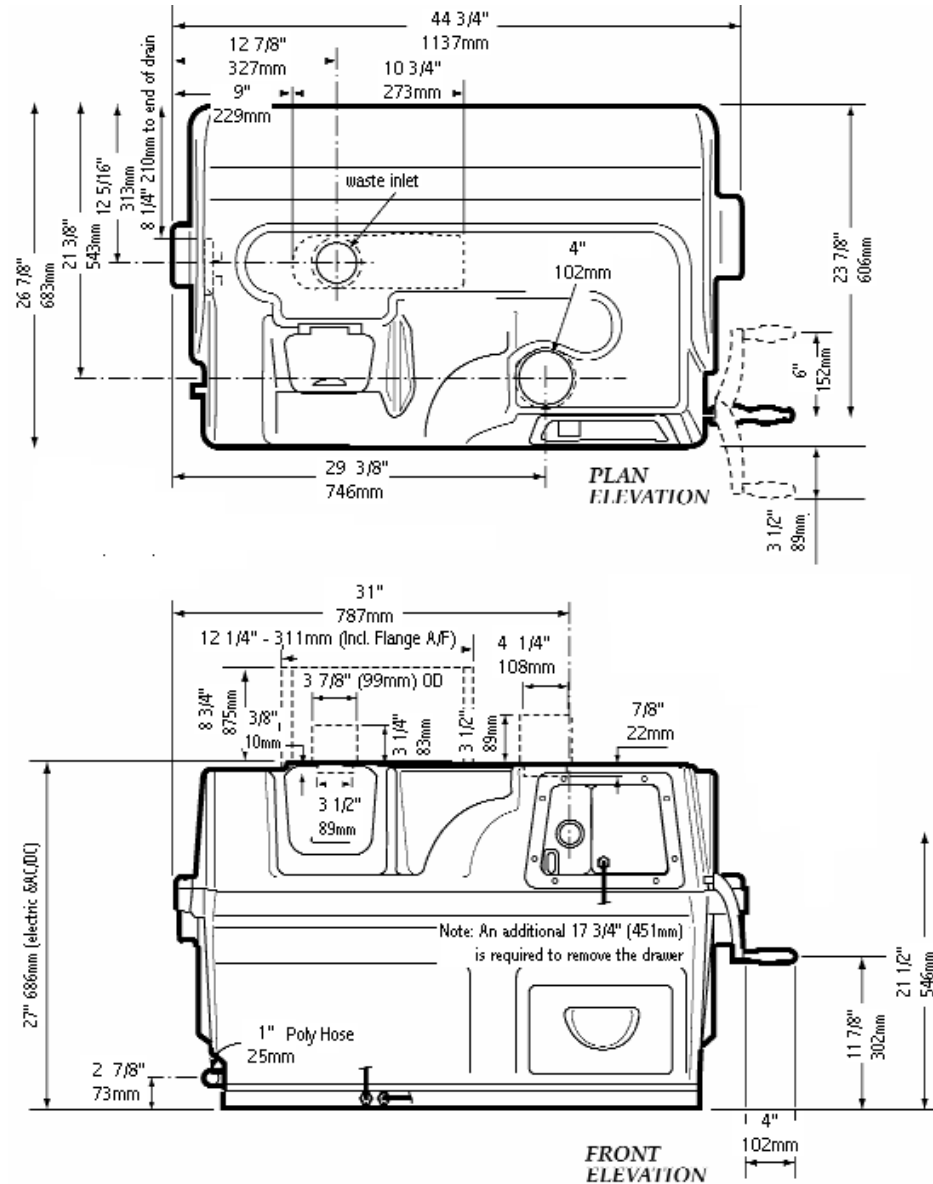

Symptom	Cause	Remedial Action	Prevention
Fan Noisy (Cont'd') (Electric and AC/DC)	Fan damaged in shipping, or bearing are beginning to wear if it is rattling.	3. If it is a vibration noise, you may need to tie down the top of the stack with guide wires and bracket the pipe that runs up the side of the structure.	
Fan Not Working (Electric and AC/DC)	Debris in fan or Mechanical Failure.	Have your serial number ready and call Sun-Mar	The fan is a continuously moving part which will eventually have to be changed. Do Not turn on and off daily.
Liquid Buildup/ Lack of Evaporation	Increased usage.	The amount of liquid varies substantially between installations. The overflow drain needs to be installed on all Centrex 2000 AF models as you will have overflow in DC mode and with heavy use on AC mode.	Install the safety drain. If the unit is being used in DC mode there will be very little evaporation.
	Failure of heating system (Electric and AC/DC)	Check "heating not working".	Rake evaporating chamber vigorously at spring startups for cottage use, and once every other month for residential use.
	Mineral salts may have accumulated in the evaporation chamber over a few years, reducing evaporation rates.	To get rid of these, fill the evaporation chamber with very hot water. Leave overnight. Drain all Liquid through the overflow drain by tipping the unit up (make sure overflow is hooked up first)	
Overflowing Liquid	Overflow drain not hooked up	Connect overflow safety drain (See also increased usage above)	
	Unit tipped forward	Check and ensure that the unit is level or tilting slightly towards the left by placing a 6mm -12mm shim piece under the right side of the unit.	

Symptom	Cause	Remedial Action	Prevention
Occasional Urine Odour Outside	1. Vent stack not installed even with peak of roof. 2. If vent stack is installed above roof peak, natural obstructions, such as tall trees, being located in a valley or close to a hill may be causing downdraft.	1. Check that the vent is installed 20-30" (60-90cm) above the peak of the roof. If not, extend the vent. Guide wires may be necessary. 2. Add lime to the evaporation chamber - as much as you think necessary. You will have to rake more often if you do this. You can also add lime to the compost if desired, but no more than 1 cup(250ml) per week as it may upset the PH balance in larger amounts. 3. Sun-Mar has a filter box available which will filter the ammonia out of the 50mm stack vented air in a downdraft situation. Call Sun-Mar for details.	Downdraft is dependent on wind direction, as well as natural obstructions, etc. Initially, install the vent 20-30"(60-90cm) above the peak of the roof. If symptoms occur, add lime or a filter box.
Strong Sewage Odour Present when drum turns	Compost is anaerobic	Begin following: "Compost Troubleshooting" suggestions.	Follow "Ongoing Maintenance" and use proper bulking material.
Fan Noisy (Electric and AC/DC)	Fan damaged in shipping, or bearings are beginning to wear if it is rattling.	1. If the fan is rattling, it may need to be cleaned or the bearings are worn and the fan needs to be replaced. 2. A hum is the normal sound the fan will make. If you are in a very quiet setting it will be more noticeable. If this is the case, consider purchasing an AC fan speed control so that the fan may be turned down when the noise bothers you. These are not available for our DC fans, but should not be necessary. 3. If it is a vibration noise, you may need to tie down the top of the stack with guide wires and bracket the pipe that runs up the side of the structure.	Clean the AC fan with a small brush and/or compressed air nozzle once every 2-3 years in cottage use, or once a year residentially. To do this, remove the fan assembly by taking off the snap cap covers and unscrewing the screws which hold it in. The entire assembly will then simply slide out. This will prevent wear and lengthen the life of your fan. Cleaning should not be necessary for the DC fan.

AF "DRY TOILET" ROUGH IN DIMENSIONS

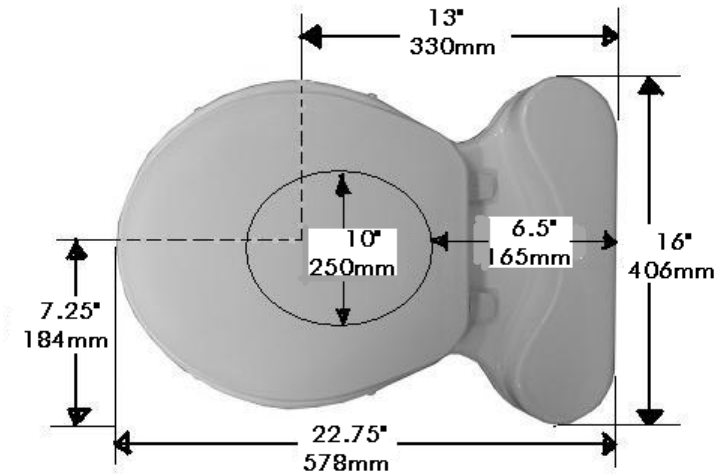

MECHANICAL TROUBLE SHOOTING

Most problems are prevented through proper maintenance and the use of proper bulking materials in the toilet. If you do have a problem which may be a mechanical or installation problem, this Trouble Shooting section will help you solve it. If you still have further questions, contact technical service at Sun-Mar for advice .

<p>Included In Your Kit</p>	<p>1- Owners Manual 1- Warranty Card 1- Evaporation Tray 1- 8'4"(256cm x 25 mm) Drain Pipe 1- Rake 1- AF Transition Piece 5- 4" x30" (100mm x 785mm) ABS Pipe (NE & AC/DC) 1- Centrex 2000 NE Hardware Kit (NE & AC/DC) 1- 12 Volt 2.4 Watt Fan (NE & AC/DC) 1- AF Silicone Kit</p> <p>1- 1 1/2" (38mm)Roof Flashing (Electric & AC/DC) 1 - 4" (100mm)Roof Flashing (NE & AC/DC) 6- 2"x30"(51mm x 787mm) PVC Pipe (Electric & AC/DC) 1- Centrex 2000 Hardware Kit 1- 4"(100mm) Diffusor (Electric & AC/DC) 1- 6"(150mm) Diffusor (NE & AC/DC) 1- 44"(112cm) Extension Pipe Piece</p>
<p>Installing the AF Toilet Base</p>	<p>The AF "Dry Toilet" comes preassembled. For the purpose of explanation, the toilet base is the bottom of the toilet which is secured to the bathroom floor, the toilet chute is the black inner section (shown in Fig. A) that fits through the floor and is attached to the toilet top, the toilet top is the upper part of the toilet that attaches to the toilet base, and the bowl liner which is the black removable funnel shaped piece below the toilet seat.</p> <p>To install the AF "Dry Toilet", follow the procedure outlined below:</p> <ol style="list-style-type: none"> 1. To locate the position of the hole, place the toilet chute in the desired location and trace the 10"(250mm) diameter cut out in the bottom of the toilet base on the floor in the bathroom. (See Fig. A) 2. Drill a 1/2"(6mm) hole on the front of traced line and then check under the floor that the hole will be clear of floor joists and will line up with the composting unit below. (See Fig. B) 3. If the position is correct, complete the cutting of the 10"(250mm) diameter circle with a jig saw. (See Fig. C) 4. Center the toilet base over the 10"(250mm) diameter hole that has been cut out of the floor and securely attach to the floor by using the four 5/16" by 2 1/2"(8mm by 64mm) lag bolts that are provided with your kit. (See Fig. D) <p>**Prior to finishing the toilet installation, it is a good idea at this time to do a pre-assembly check to see if you will need any extension pipe</p>
<p>The Transition Piece</p>	<p>Place transition piece(Fig. E) into the waste inlet hole on the top of the Centrex 2000 AF composting unit. Make sure that the transition piece is completely vertical on the unit, or completely vertical. It is important that the transition piece is not tilted so that waste can drop directly into the composting drum.</p>

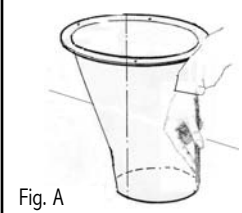

Fig. A

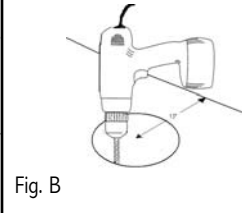

Fig. B

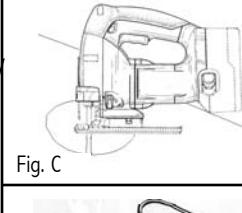

Fig. C

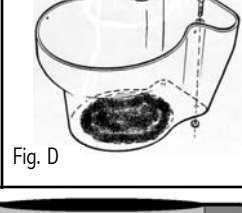

Fig. D

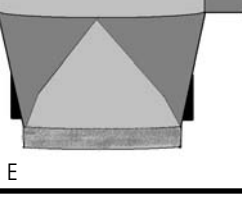

Fig. E

Symptom	Cause	Remedial Action	Prevention
<p>Urine Odour around Centrex 2000 AF</p>	<p>Horizontal runs or downward slopes on pipe are causing condensate to block 50mm vent pipe.</p>	<p>Re-install the vent so there are no longer any low points where condensate can collect. If re-installation is not possible, drill a small hole in the bottom of the low point (preferably outdoors) to allow condensate to drain. (Note: watch for icing in winter at this hole.)</p>	<p>Install wall brackets on vent pipe to prevent settling. DO NOT install horizontal runs as liquid will collect and block ventilation, causing odour.</p>
<p>Fan has failed (AC or DC mode)</p>	<p>Have your serial number ready and call Sun-Mar for a replacement. Instructions are included with the replacement fan.</p>	<p>The fan is a constantly moving part and has a finite service life.</p>	
<p>Device other than Sun-Mar diffusor is installed on top of the vent stack</p>	<p>Wind turbines or vent caps may be discouraging air movement. If so, replace with a Sun-Mar diffusor.</p>	<p>Wind turbines or vent caps should not be installed on or, instead of a Sun-Mar diffusor.</p>	
<p>Room where unit is located is airtight.</p>	<ol style="list-style-type: none"> 1. Hold a lighter up to the air intake holes on the back of the unit. Air should be drawn into the holes. If air is not easily pulled in, check venting for too many bends or horizontal lengths and/or provide more ventilation to the room. 2. Install fresh air intakes on any competing appliances. 	<p>Install your Centrex 2000 AF in an area with plenty of ventilation and watch for competing appliances such as bathroom fans and wood stoves.</p>	
<p>50mm vent stack has too many bends and/or horizontal lengths.</p>	<ol style="list-style-type: none"> 1. Re-install the 2"(50mm) vent stack to reduce the number of bends/eliminate horizontal lengths. 2. If the vent stack cannot be further straightened, remove the AC fan assembly and reduce the amount of recirculating air by adjusting the fan gate (see page 14). 	<p>Install the vent with minimal bends (total bends should equal no more than 360 degrees) and NO horizontal or downward slopes.</p>	
<p>Not enough air being pulled down the dry toilet</p>	<p>Two 3"(75mm) diameter air intake holes covers are supplied with the hardware kit. One or both of the air intake holes at the rear of the unit, may be covered so that more air is pulled down the toilet.</p>	<p>Covers should only be inserted if they are needed, because insertion reduces airflow over the evaporation chamber, which in turn reduces evaporation performance.</p>	

Symptom	Cause	Remedial Action	Prevention
Flies Present	-compost too dry -compost anaerobic -kitchen/garden waste added -foreign material added	<p>1. To get rid of flies, you can use any pesticide that is used on your garden. Pesticides used for garden use are not anti-bacterial so are safe to use on your compost. If you prefer not to use a pesticide in your compost, the unit should be cleaned out completely and washed with soapy water to kill any remaining eggs. Once the unit is washed, it should be rinsed well to remove all traces of soap before restarting the compost.</p> <p>2. If using a pesticide to kill the insects, it may be purchased from a local garden center or hardware store.</p> <p>3. If using a liquid, sprinkle about 1/2 cup (125ml) of the mixture directly over the compost. Using a spray bottle, apply throughout the entire toilet (finishing drawer, evaporating chamber, drum, out side of drum) until the fly population is eliminated. Open a window or door to ventilate the room while applying and keep children and pets away from the area for a few hours after application. Repeat if you see another fly after the initial application.</p> <p>IMPORTANT: Application of a pesticide in a Sun-Mar composter is not a health concern because all Sun-Mar units are vented.</p>	<p>1. Keep compost moist. In order to determine a good level of moisture, shine a flashlight into the drum. The compost should have a slight gloss or shine. If it does not, add warm water to it until it reaches this consistency. Fungus gnats tend to be attracted to a dry compost, due to the fungus which begins to form on the surface when it dries out. A good, moist compost will not be attractive to flies.</p> <p>2. Do not add topsoil from the ground, composted matter, or kitchen scraps to the toilet. Flies may be present in, or attracted to these items.</p> <p>3. If toilet is installed over an old septic line, make sure that the lines are well sealed. Insects find unused lines attractive.</p> <p>4. See "Compost Remediation" if the compost smells- anaerobic compost will attract flies and drastically reduce the performance of your composting unit</p> <p>5. Use a mixture of peat moss and non-antibacterial wood shavings.</p>

Determining if an Extension Pipe Piece is Needed	Place the toilet chute into the toilet base in the bathroom. If the toilet chute extends 1-2"(25 - 50mm) into the transition piece, then no extension pipe pieces will be required. If the transition piece does not extend far enough up to meet the toilet chute, then one or more extension pipe pieces will be needed. These minimum 44"(112cm) pipe sections can be cut down to the correct length, so that when assembled and placed in the transition piece, they extend 1-2"(25-50mm) into the toilet chute. After taking into account the overlap, each pipe piece provides an extension of about 41"(104cm).
Assembling and Installing the Extension Pipe Pieces (If Needed)	<p>A pipe section, which comes in two halves, can be cut to the correct length, by cutting the required amount off the straight ends of each half with a hack saw.</p> <p>It is easier to cut pipe sections to length before joining the two halves together. After cutting, clean up the edges with a sanding block and coarse (40-60 grit) sandpaper.</p> <p>Before joining the two halves of the pipe pieces, spread a bead of silicone caulking from top to bottom along the inside of both halves of pipe pieces (so that the inside of the pipe section will be sealed). Press the two halves together, and secure them by screwing the self tapping screws provided into the pre-drilled holes. Run a finger or spatula up along each joint inside the chute to remove any excess silicone. Ensure that when the pipe pieces are assembled together, and the bottom piece is placed in the transition piece of the composting unit, so that the top of the transition piece extends 25-50mm over the chute or extension pipe piece.</p>
Finishing the AF "Dry Toilet" Installation	<p>Pre Assembly Check: Before finishing the installation, make sure everything fits together properly. The top of the pipe piece is belled out to accommodate the toilet chute. Place the transition piece in the cut out provided on the top of the composting unit. Place the pipe pieces, if any, inside the transition piece. Next lower the toilet top onto the base so that the chute projects 1-2"(25-50mm) into the pipe piece or directly into the transition piece if no pipe piece is used. Ensure that the toilet top is properly located over the toilet base, that the chute is completely vertical, and that the screws to attach the top to the toilet base, line up properly. (Fig. A) If the pre-assembly check appears OK, then disassemble and reassemble each piece as in the pre-assembly check(see above).</p> <p>To assemble the toilet top with the chute, line up top with the chute and fasten the four screws around toilet opening and cover with the snap caps (Fig B). Insert the toilet chute into the toilet base until the toilet top rests on the base (Fig C). When reassembling use silicone caulking at the joints where the toilet chute sits inside the extension pipe piece, where the extension pipe piece sits inside the transition piece and where the transition piece sits inside the composting unit. Use a finger or spatula to remove any excess silicone.</p> <p>Next, line up the two pre-drilled holes which go through the front of the toilet top through into the toilet base, and insert the two screws without tightening them. With these front two holes secured, tilt the rear of the top down over the base until the last four screws are located. Screw in all six screws, making sure not to over-tighten, and push on the plastic caps over the screw heads. Attach the toilet seat by threading the nylon screws through the toilet seat hinge and into the holes into the toilet top. Put the black removable bowl liner into place under the toilet seat.</p>

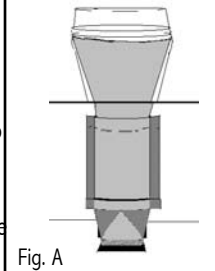

Fig. A

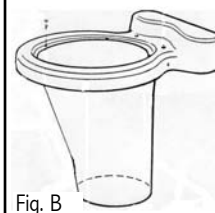

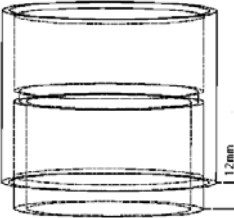
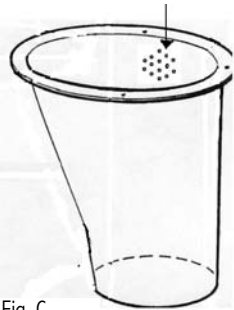

Fig. B



Fig. C

Adjusting the Air Intake	The Centrex 2000 AF composting unit has a 3”(75mm) diameter air intake hole at the rear of the unit, just above the floor of the evaporation chamber. A 3”(75mm) intake cover is supplied with the hardware kit in the composting unit. The air intake can be removed and replaced with the 3”(75mm) intake cover if it proves necessary to pull more air down the AF “Dry Toilet” chute. This cover should only be inserted if it is needed, because blocking the air intake will reduce the airflow over the evaporation chamber, which in turn reduces evaporation performance.	
Installing the Optional Vent on the AF “Dry Toilet:”	<p>If the air intake cover is in place (See “Adjusting the Air Intake Covers” above), but the toilet is more than one extension pipe piece above the composting unit so the fan is unable to draw air down through the toilet chute, then it is necessary to vent the toilet directly. The toilet itself should be vented as follows:</p> <ol style="list-style-type: none"> Obtain sufficient pipe and fittings for the vent using either 3”(75mm) sewer pipe or plumbing pipe. Trace the outside outline of the pipe on the circular section at the top and rear of the toilet top at either the left or right of the toilet top depending on which side it is more convenient to vent from. (See Fig. A) Cut out the hole by first drilling a hole in the circumference of the traced outline, and then carefully using a jig saw to complete the circle. Sand to enlarge or smooth off the edges if necessary. Cut a short length of pipe and glue it into a connector, with 1/2” (13mm) of pipe protruding from the connector. Place this protruding end in the newly cut hole to locate the base of the vent stack. (Fig. B) Erect the vent stack as vertically as possible following the same rules as outlined on page 14, in the vent pipe location section. If it is not possible to make this vent vertical or close to vertical, a 12 Volt fan may also have to be installed in this vent stack. Since the 12 Volt fan comes in a 12”(300mm) length of 4”(100mm) sewer pipe, transition coupling will be needed if 3”(75mm) pipe has been used. 	 <p>Fig. A</p>  <p>Fig. B</p>  <p>Fig. C</p>
Cutting Holes in the Toilet Chute	Remove the bowl liner in the toilet top, and drill out a large number (15-20) holes 1/4”(6mm) or bigger at the top rear of the chute piece no more than 3”(75mm) down from the top edge. (See Fig. C) These holes will enable the vent on the top of the toilet to draw air up the chute.	
Drain Installation	The 1”(25mm) Safety drains at the left of the “Centrex 2000 AF Family”, exit to both the front and back. To connect one of the drains, (whichever is convenient), remove the plug, attach the 1”(25mm) hose (included) and secure with a hose clamp. Ensure there are no kinks or upward bends in the drain hose.	

Symptom	Cause	Remedial Action	Prevention
Waste not Breaking Down at all (cont'd)	Antibiotics being used for more than a few weeks on a continuous basis may kill bacteria.	Empty drum. Hose out inside of drum. Restart compost according to “Initial System Startups”.	When used normally, antibiotics will only slightly slow compost. Add compost accelerant during this period to accelerate compost action. Urinating elsewhere during this period will also help minimize the damage to the compost.
Lumps <i>If many large lumps have formed in drum, you will need to remove them or break them up with the rake tool. Follow the prevention column to ensure this does not happen.</i>	Compost Too Dry	Follow instructions for “Compost Too Dry” above. And also add 1-2 QUARTS(2 liters) of warm water.	Follow recommendations for checking and adding moisture in “PERIODIC CHECKUP”.
Over-Rotation of Drum		Follow “ONGOING TOILET MAINTENANCE”, and also add 1-2 QUARTS(2 liters) of wood shavings.	Drum should be turned three times a week, 6 rotations each time; once before departure for weekend use.
Peat moss used as bulking material with no wood shavings.		Begin using 70% wood shavings, 30% peat moss as bulking material.	Use proper bulking material.
Drum Too Full <i>Note: The drum is too full when it is over 1/2 full, and the door is not closing properly.</i>	Compost not emptied into finishing drawer in a timely fashion.	<ol style="list-style-type: none"> Remove compost until drum is only half full or less. Rotate compost thoroughly to aerate, and add compost accelerant if available. If you need to dump more than one drawer of compost, and you do not already have a suitable backyard compost heap, you may try an open-slatted wooden crate (such as the kind used to pack age fruits and vegetables). Layer compost with bulking material and leave crate outside for around 2 months to finish composting. 	When drum is 1/2 full, remove some compost to the finishing drawer by rotating the drum backwards, to avoid surprise over-filling of drum. Do NOT let drum get above 1/2 full. (The drum is 1/2 full when the level of the compost reaches 4-6”(100-150mm) below where the drum door hangs) This will lead to lack of aeration, and anaerobic compost, and the inconvenience of having to remove more than one drawer.
Kitchen/Garden Waste added			Do Not add kitchen or garden waste.

Symptom	Cause	Remedial Action	Prevention
Compost Too Wet <i>Your compost is too wet when there are standing pools of liquid. Compost will smell of sewage and is anaerobic</i>	Compost porosity is poor. Too much peat moss has been used as a bulking material. This is compacting, preventing liquid from draining through, and leaving no free air space for oxygen.	For an immediate improvement in porosity add about 2 liters of wood shavings, of any kind (except cedar, cypress, juniper, bamboo, teak, redwood, eucalyptus, sugar cane, or any other woods with anti-bacterial properties) to the drum. On an ongoing basis, change bulking material a mixture of 60% wood shavings and 40% peat moss mix.	Use 40% peat moss, 60% wood shavings as a bulking material.
	Drum screen clogged	Remove the finishing drawer. Scrub screen (which will be visible with a flashlight on the bottom of the drum) with wire brush. The overflow drain should be hooked up.	
Compost Too Dry <i>Compost is too dry when compost looks flat and brown rather than rich and black.</i>	Moisture not being added periodically or before departure on cottage units. Toilet not used for urination .	Add 2 to 4 litres of warm water to compost in order to bring it up to appropriate moisture level.	Follow section on moisture in "PERIODIC CHECKUP".
	Insufficient bulking material or not enough peat moss.	Peat moss retains moisture. 40-60% moisture content is ideal for aerobic microbes to thrive.	Use toilet for urination. Add correct bulking material.
Waste not Breaking Down at all <i>If this is the case, the drum will fill up quickly</i>	Insufficient Microbes	Add compost accelerant or unsterilized black earth from a garden center.	Be sure to add compost accelerant at startups.
	Temperature around unit under 15C	Install heat source to increase temperature. Temperature should be kept above 13 -15C constantly if toilet will be used on an ongoing basis.	Install unit in warm area. The warmer the area, the better your compost will be! If evening temperatures fall below the prescribed temperatures on a residential unit, consider installing a heat source on a timer for evenings.
	Bleach or other anti-bacterial chemicals added.	Empty drum. Hose out inside of drum. Restart compost according to "Initial System Startups".	Never add bleach or cleaning chemicals.

Handling Effluent	<p>The following are possible options to take care of the liquid:</p> <ul style="list-style-type: none"> - Use a container which is emptied periodically (water jug or small barrel). This ensures a closed loop system. - Feed into a lined pit filled with gravel and sand. Such a recycling bed also ensures a closed loop system. - Feed into a small cesspit or "french drain". - Plumb into an existing septic or holding tank line. <p>Installation should be in accordance with applicable local regulations.</p>	<p>All installations should conform to</p>
Vent Piping Location	<p>Piping can be installed up the inside wall; through the wall at a slight angle and up the outside wall. The choice depends on ease of installation, visibility, and (especially if the toilet is to be used consistently through a cold winter), the necessity of insulating all exposed vent pipe.</p>	<p><i>The vent on the right is a 4"(100mm) on-electric vent. All others show possible 2"(50mm) Centrex 2000 (electric) vent configurations.</i></p>
Adjusting the fan gate (Electric and AC/DC)	<p>If you believe that there may be a downdraft outside of the building, it may be a good idea to remove your fan assembly prior to installation and set the fan gate to '0' to prevent urine odour in the bathroom. The fan gate is factory set to '3', which recirculates air within the unit. If there is a downdraft you may get blow back into the room where the unit is installed. When setting the fan gate to '0', you may lose some evaporation so it is also wise to hook up the emergency drain.</p>	
Vent Piping Installation	<p>Piping and fittings are of standard 2"(50mm) PVC thin wall tubing(central vacuum) and/or 4"(100mm) PVC thin wall pipe. Additional pipe or fittings can be purchased from a building supply dealer. If you cannot find them near your location, you can substitute schedule 40 pipe and use a rubber coupling to join this pipe to the unit.</p> <ol style="list-style-type: none"> Minimize the number of sharp angles in the 2"(50mm) vent as each reduces vent efficiency. The 4"(100mm) vent should be installed as near to vertical as possible. If it is necessary to have angles in the 4"(100mm) vent pipe 45 degree angles are used whenever possible. On the 4"(100mm) DC stack, bends should be limited to 2 - 45 degree angles. This will necessitate the installation of a 12 volt fan. Do not lead the 2"(50mm) vent pipe downward or horizontally at any point. This may lead to the 	

Chapter 4 Compost Troubleshooting

This chapter will deal with problem that may arise with your compost, what is required to make your compost healthy and how to correct problems if they arise.

Aerobic Compost Requirements

In a Sun-Mar, a good compost is predominantly aerobic, which means that oxygen is available for aerobic bacteria throughout the Bio-drum. Aerobic bacteria consume waste quickly and odourlessly to produce carbon dioxide and water vapor and leave behind a small fraction of the original waste volume in the form of basic minerals. The end compost is a mix of valuable minerals and bulking material that has not decomposed.

To work effectively to break down waste, aerobic bacteria need oxygen, moisture, available carbon (from the bulking material), and warmth.

In a Sun-Mar, oxygen is provided by the tumbling of the drum and the bulking material leaving free air space within the compost. Moisture is provided by the waste, and is made available to aerobic bacteria by the moisture retention properties of the bulking material. If the compost is too dry, add warm water.

In summary, to keep the compost aerobic, it is important to rotate the drum, add bulking material, and keep the compost moist.

Oxygen

Lack of oxygen becomes a problem where:

- Too much moisture eliminates the free air space,
- A lack of bulking material limits free air space,
- Aerobic bacteria use up oxygen in the compost.

Lack of oxygen causes the compost to become increasingly anaerobic, which means that aerobic bacteria are displaced by anaerobic bacteria. Anaerobic bacteria work slowly and produce undesirable ammonia, hydrogen sulphide, and methane. Consequently, the maintenance of 'free air' space by periodically rotating the drum and adding the right bulking material is very important in Sun-Mar units. Excessive rotation is not helpful and can harm the compost by disturbing the bacteria too much.

Moisture

If there is too much moisture, and the compost is approaching saturation, oxygen is pushed out and anaerobic activity predominates. On the other hand, if there is too little moisture, aerobic activity slows. For this reason, it is important to maintain adequate moisture levels (40-60% moisture content is ideal). Generally, if you shine a flashlight in after mixing, there should be a slight sheen of moisture on your compost.

Warmth

Too little warmth will cause aerobic activity to slow. Below 13-55F(15C) degrees, microbes will go dormant and composting will stop. Composting speeds increase dramatically with temperature.



Characteristics of a Bad Compost

If your compost is over 8 weeks old and it exhibits one or more of the following characteristics, then an operating change is indicated.

- ✓ Extraction required too often (under 4 weeks)
- ✓ Large Lumps present in compost
- ✓ Compost muddy or clay-like
- ✓ Flies present (this may also be a problem with foreign matter being added to unit; see section on flies)
- ✓ Compost has strong unpleasant smell of sewage when drum is turned.
- ✓ Toilet paper present in finishing drawer

Troubleshooting

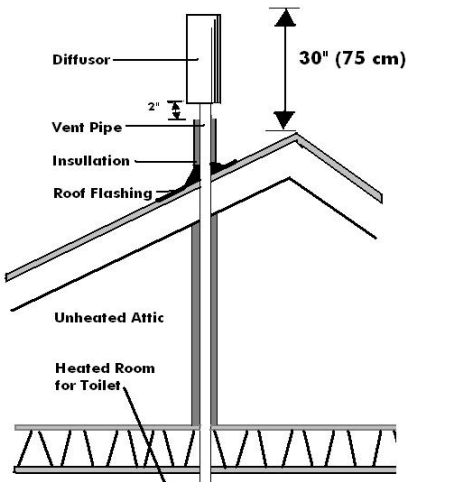
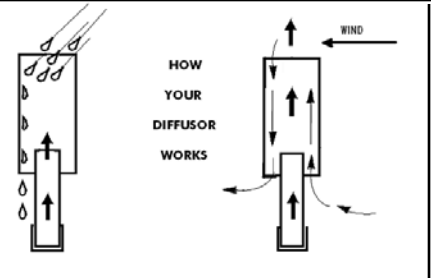
In using this troubleshooting section, you should follow remedial actions in the order that they are given, unless you are sure of the problem. You should see improvement in a week, and your compost should be back to normal in 2-3 weeks. If it is not, make sure that "Ongoing Toilet Maintenance" is being followed and check the mechanical troubleshooting section.

Vent Piping Installation (Cont'd)	<p>vent pipe being blocked by condensation which would cause a urine smell in your bathroom.</p> <p>iii) All connectors in the vent pipe should be sealed. Use silicone for the connection of the vent stack to the toilet in case the composting unit has to be moved or you have to access the fan. PVC cement may be used in the rest of the stack installation if desired.</p> <p>iv) All exposed 2"(50mm) vent pipe should be insulated with the foam insulation. This is especially important for winter or residential use to prevent condensation.</p> <p>v) The Sun-Mar 12 Volt fan is fitted inside a 12"(300mm) length of 4"(100mm) vent pipe for easy installation, should it be needed. It is installed by either cutting out a section of the vent immediately above the composting unit, or by raising the vent stack off of the composting unit and inserting the fan section. The fan can be used with a solar panel and 12 volt battery, or by purchasing a 12 volt adapter from your local hardware store and simply plugging it into the wall.</p>	
Leading the vent through the roof	<p>As shown in the installation, the vent stack should end about 20-30"(60-90mm) above the peak of the roof so that it is less subject to downdraft. Where the piping is taken through the roof, the roof flashing provided should be used to seal the installation. Insert the vent into the bell of the roof flashing and slide the roof flashing down until it lays evenly on the roof. Slip the upper edge of the roof flashing flange under the shingles. Outline the flashing on the roof. Raise the roof flashing and apply silicone sealant or roofing tar inside the outline. Slide the flashing back into place and firmly press onto the sealant. The flashing is properly placed when the top part of the roof flashing flange is tucked under the shingles and the lower portion is sealed on top of the shingles so that water sheds easily. Secure the flashing with corrosion resistant nails at each corner and along sides. Any exposed nails should be sealed with silicone caulking.</p>	
The Diffusor		<p>The diffusor provided with the unit is a simple device to be installed at the top of the vent stack with the larger pipe protruding above the smaller. To install, simply glue the diffusor on the topmost section of vent pipe. The diffusor design encourages updraft, and discourages wind and weather from going down the vent stack. Unlike wind turbines, diffusors are less likely to freeze up in winter, and are more effective in calm weather.</p>
Electrical Considerations (Electric and AC/DC)	<p>A ground fault circuit interrupter (GFI) is recommended to protect your composting unit from electrical problems. This may be installed directly on the wall socket or at the circuit breaker. An example is shown in the picture at the right.</p> 	

Ongoing Toilet Maintenance

The procedure below is designed to keep the compost:

- **Moist, but not too wet**
- **Well aerated and mixed**
- **Well balanced and aerobic**

Action	Reason for Action
<p>Add 1 cup(250ml) or 2 handfuls of a mixture of 40% peat moss and 60% non-antibacterial wood shavings to the Bio-Drum per person per day of use.</p>	<ul style="list-style-type: none"> - Maintains the carbon/nitrogen balance - Absorbs liquid - Helps oxygen penetrate for aerobic composting
<p>Turn Handle to rotate the drum a minimum of 6 complete revolutions every second day when in use. Pull the drum locker button and turn the drum 1/2 turn past its' resting position to level the compost inside the drum. To prevent a mess, DO NOT forget to return the drum opening to a position under the waste pipe.</p>	<ul style="list-style-type: none"> - Mixes and oxygenates the compost
<p>Unplug the unit if you are leaving for a period of more than a few days. If you are leaving one weekend and coming back the next, you may unplug the unit. If you are leaving for a period of more than a few days, or the compost appears dry, add approximately 1 quart(2 liters) of warm water to keep the compost moist.</p>	<ul style="list-style-type: none"> - unplugging unit will conserve power and keep compost from drying. - addition of water helps keep the compost moist
<p>Remove compost into the finishing drawer when the drum is 1/2 full. It is 1/2 full when the compost reaches a level about 100-150mm below the bottom of the drum door when the door is open.</p> <p>To empty some compost into the drawer, pull the drum locker button and rotate the handle counter-clockwise (to turn the drum clockwise). Turn at the same speed you would normally do for mixing. This will fill the finishing drawer. Compost in the drawer should then sit in the drawer, in the unit to finish composting for at least 2 months before the drawer is emptied. If necessary, use the rake to level the compost in the drawer. If there is not enough compost in the drawer, turn the drum backwards (clockwise) again 1 rotation.</p> <p>We recommend storing compost in a container before using.</p> <p>If your unit is used seasonally and is not used heavily, you may not have to remove any compost at all during the season. If so, follow "Annual Startups".</p>	<ul style="list-style-type: none"> - Moves some compost to the next stage for finishing - Ensures that the drum does not get too full - Provides extra time for composting to be completed

12 Volt Fan Installation (AC/DC and NE)

Every Sun-Mar AC/DC and NE model comes with a 12 Volt Fan for installation in the 100mm stack. Its installation is required in the following situations:

- If you are installing both 2"(50mm) and 4"(100mm) vent stacks (prevents downdraft from the 2" or 50mm vent)
- If you are in an area where you are subject to downdraft
- If you are using the unit residentially
- If you need to install the vent stack with bends

We include it because many AC/DC owners do install both vent stacks. It may also be installed later if you wish simply by cutting a section out of your vent and replacing it with the fan.

To install the fan initially, pick a spot on the stack that you can reach easily. In order to get the best evaporative performance from the fan, install it near the composting unit if possible (remember, the fan will still not be enough to evaporate all liquids in a non-electric or DC only environment). Once you have placed it where you wish, use silicone caulking, or rubberized couplings, to make the installation airtight. Do not use glue as you may need to change the fan at a later date.

The 12 Volt Fan may be powered with a battery that is connected to a generator, solar panel, or other alternative energy system. For use in AC, purchase a 12 Volt to AC Adapter from any electrical store and snip off the female end - wire the positive wire to the red wire on the fan, and the negative wire to the blue wire on the fan. Tie them off with small wire connectors, and plug your AC Adapter into the wall.

The 12 Volt Fan should be continuously running if used, as if it is not running it will act as a block in the vent stack.

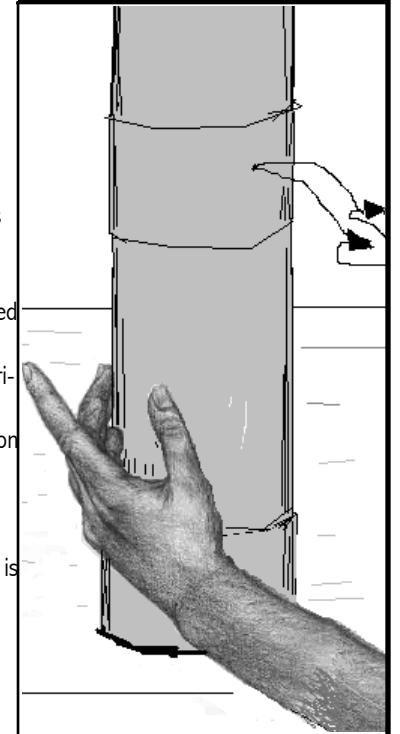

Chapter 3

Start Up and Use

Although the start up instructions remain the same no matter what your application, different situations will require different actions and this chapter will explain what they are.

Initial System Start Up

Begin operation by carrying out the start up procedure described below, and then continue with the “Ongoing Toilet Maintenance” routine. It normally takes six weeks before a compost is properly established. You will know this has happened when:

- **Compost Volume increases more slowly**
- **Compost turns black and becomes loam-like**
- **Toilet paper decomposes within a few days**

	Action	Why?
ADD	8 gallons(30 liters) of bulking mixture (60% shavings and 40% peat moss) to the drum.	-Provides carbon base and initial mass for compost.
ADD	Compost accelerant	-Adds necessary microbes which will breakdown the compost.
SPRINKLE	About 1gallon(4 liters) of warm water into the drum	-Moistens carbon base
PLUG IN	Fan and heater are operating	-The unit is ready for use
RAKE	Loose peat moss from the evaporating chamber until the compost is established, which takes approximately 6 weeks.	-Until the compost is active, some peat moss may fall through the screen or drum door into the evaporating chamber
POSITION	Black evaporating tray under drum screen to the left of the drawer.	Extends the surface area of evaporation chamber

* Toilet paper is a good source of carbon and should be added after use.

CAUTION

1. Do **NOT** add or clean the toilet bowl with chemicals. Chemicals will kill the bacteria.
INSTEAD, clean the bowl hot water and baking soda or a weak vinegar and water solution.
2. Do **NOT** add plastic, glass, metal, cleaning fluids, cigarettes. Add only waste and bulking material.
3. Kitchen or garden waste are **NOT** recommended.

Annual Start Up (seasonal units only)

Many units are only used regularly throughout the summer. For such seasonal units Sun-Mar recommends that the following start up procedure be followed at the beginning of the season.

Action	Reason for Action
Empty the compost that had been left in the finishing drawer, and use the rake to clean out the evaporation chamber.	- Your fertilizer is ready. - This is a good time to remove peat debris
Remove additional drawers of compost (if there is more than 6-8" or 150-200mm in the drum), by releasing the drum lock (white button on right side of unit), and rotating the drum clockwise (the handle turns counter-clockwise) to extract compost into the drawer. (At the beginning of the season, it will all be finished compost) Empty the drawer and repeat extraction cycle until the level in the drum is reduced to about 6"(150mm).	- Frees space in the composting chamber for the new seasons composting.
Add 1 gallon(4 liters) of warm water.	- Raises moisture level
As an option for optimal composting, Add composting accelerant. We do not recommend using topsoil as it may contain fly larvae.	- Even though the compost still has microbes in it, you may want to start the year by replenishing your batch of microbes.

Periodic Check Up

Once your unit has been through initial or annual start-ups, and ongoing maintenance procedures are being followed, Sun-Mar recommends a system of periodic checks be undertaken.

Action	Reason for Action
Rake solid debris from the evaporation chamber, making sure to rake from the rear of the chamber, including the back two corners nearest to the drains of the unit. Raking should occur on a twice yearly basis for cottages (best done at annual startups and half way through the season), and a bi-monthly period for continuous users.	- Ensures drains cannot get plugged and evaporation is improved.
Check your compost moisture level on each visit for cottage users and once every two weeks for continuous users. This can be done by shining a light into the Bio-Drum. The compost should have a slight gloss or shine to it. A moisture meter may also be used if so desired. Range should be 4-6, which represents 40% to 60%	- A good compost is between 40% and 60% moisture content. - Prevents lumps, ensures toilet paper breaks down quickly. - Prevents insects
Pour 1 gallon(4 liters) of warm water down the toilet.	- Ensures waste piping remains free-flowing.